

veritas[®]
Low-Angle Spokeshave



05P32.01

The Veritas® Low-Angle Spokeshave is configured like a traditional spokeshave, with the blade positioned bevel up. This arrangement allows for the lowest possible cutting angle, determined by the bevel angle of the blade. The blade comes honed with a 25° micro-bevel and is made of 1/8" (0.125") thick A2 tool steel. The body is lightweight cast aluminum, shaped for comfort and maximum control. The anodized aluminum toe piece can be adjusted to set the depth of cut, and is designed so that it can be used for standard flat cutting or flipped over for work on tight curves (see **Figure 3**). The mouth can be adjusted by setting the blade position as required (a narrow slit for fine shavings with minimum tear-out or fully open for heavier cuts). The two blade locking knobs are solid brass and the two steel blade stems rigidly secure the blade.

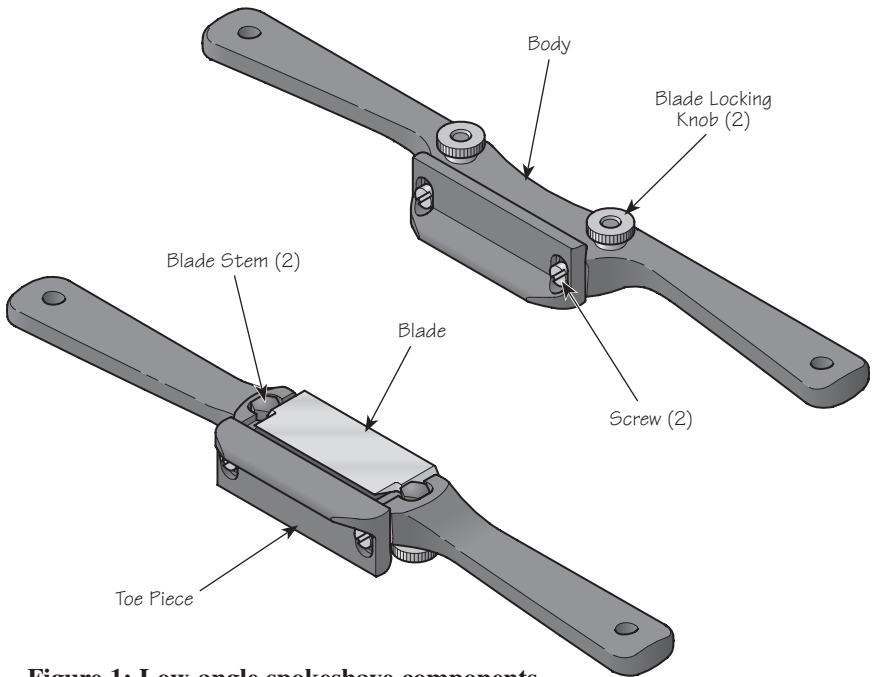

Figure 1: Low-angle spokeshave components.

Instructions For Use

Firmly grip the spokeshave with both hands. Position your thumbs directly on the shaped toe piece for maximum control. The orientation of the blade relative to the workpiece is controlled with the wrists. As with any wood-cutting blade, a relief angle is required between the surface of the workpiece and the bottom of the tool (in this case, the bottom of the blade), due to fiber springback. Tilt the spokeshave forward slightly to achieve a relief angle. While this will require some practice and feel, the sole of the toe piece is shaped so that it is at a slight angle and will help guide you to the desired relief angle.

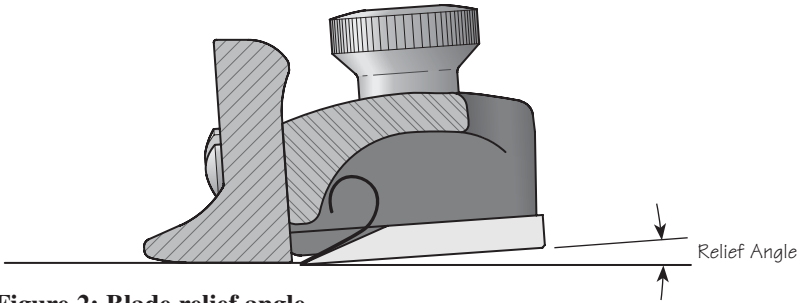

Figure 2: Blade relief angle.

Should you attempt a cut while keeping the bottom of the blade in complete contact with the workpiece, the spokeshave will tend to glide along the wood instead of cut it.

Skewing the cut, or holding the spokeshave askew or rotated with reference to the path of travel will yield the best results. This orientation lowers the effective cutting angle and adds a slicing force to the cut.

The Veritas Low-Angle Spokeshave is designed for use with either a pulling or pushing action. This allows you to always work with the grain, which is particularly important when working with a low cutting angle. On more complex shapes, this may involve frequent changes of direction, flipping the tool and pulling or pushing as required.

The toe piece can be flipped to permit work on tighter inside curves. Remove the two front screws (and washers) that secure the toe piece, flip the toe piece over (as shown below), replace the screws (and washers), reposition to achieve the desired depth of cut (see *Depth of Cut*), and retighten the screws.

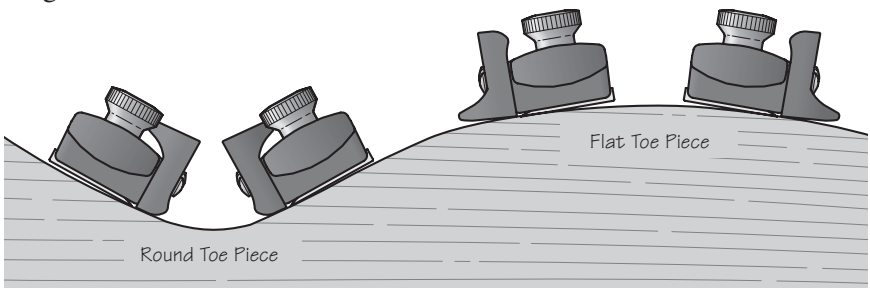

Figure 3: Orienting the toe piece.

Depth of Cut

The depth of cut is determined by the position of the toe piece relative to the blade. Raise the toe piece to increase the depth of cut or lower it for a finer cut. Loosen the two screws and position the toe piece as required. Tighten the two screws and take a test cut.

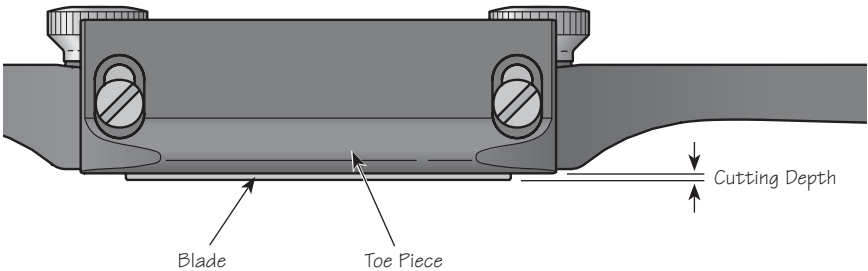

Figure 4: Adjusting the depth of cut.

The low-angle spokeshave is intended for fine, precise work, not the heavy material removal accomplished with a drawknife. The maximum depth of cut will vary with the material being worked – greatest in green softwood and much less in dry hardwood. A cut that is too aggressive will result in excessive force on the blade and may cause it to shift or come off the tool.

To achieve consistent and predictable cutting, you could set the toe piece and blade parallel to one another. However, by setting the toe piece at a slight angle so that one side is higher than the other, you can achieve cuts of differing depths without having to stop and reset the toe piece. With the right side of the toe piece set higher, you could make larger, roughing cuts with the right side of the blade and then shift over to the left side of the blade for finer, finishing cuts. This, of course, works only when the contact area of the workpiece is substantially less than the width of the blade.

Mouth Adjustment

The blade can be readily repositioned to accurately set the gap between it and the toe piece (this opening is called the mouth). Generally, you will want an opening as small as will allow the shaving to escape. The reason for this is that a tight mouth supports the wood ahead of the blade, preventing break-out and, most important for low-angle cutting, reducing the tendency of a shaving to split away from the surface of the workpiece. Loosen the two blade locking knobs and adjust the position of the blade by sliding it forward or backward as required. Tighten the knobs firmly, but avoid overtightening.

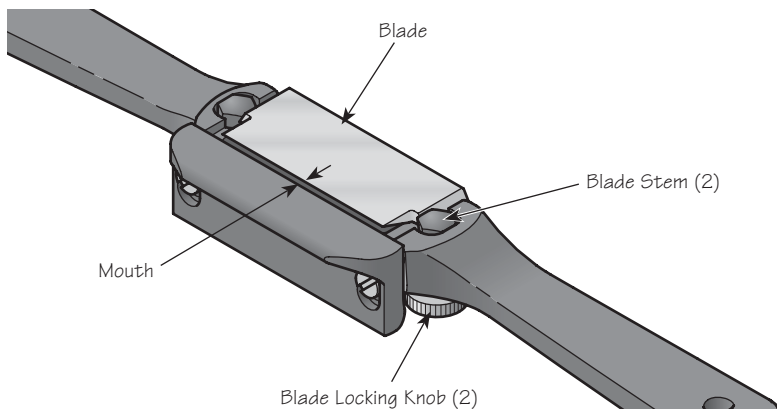

Figure 5: Adjusting the mouth.

***Note:** If working wide stock, check that neither blade stem projects below the surface of the blade. If one blade stem is too low, loosen the knob on the other stem and retighten the knob of the stem that is too low, drawing it up.*

***Note:** The mating surfaces between the blade and the body, and the blade and the stem, can be quite smooth. As such, the blade may slip in use when dealing with harder woods or heavier cuts. To ensure the blade remains securely clamped when using the spokeshave, thoroughly clean the mating surfaces with a suitable solvent to ensure they are free of lubricants/waxes, etc. Also, scuff the blade (perpendicular to the slip path) on the top face where it mates with the body and on the bevelled ends where it mates with the blade stems, using 60 or 80 grit sandpaper.*

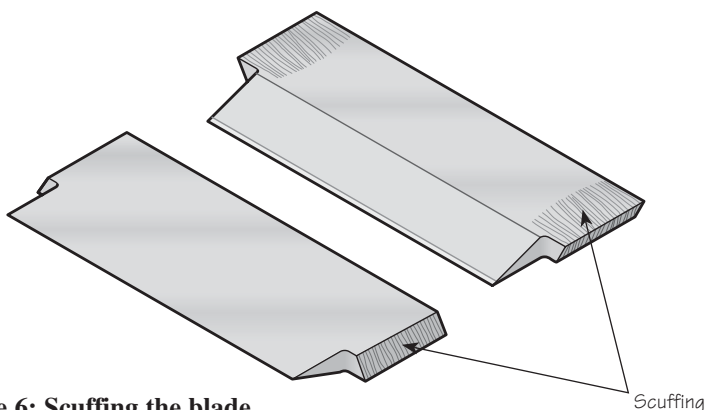

Figure 6: Scuffing the blade.

Blade Sharpening

The Veritas Low-Angle Spokeshave blade has been honed ready for use. It comes with a primary angle of 20° and a micro-bevel of 25° . This allows you to easily resharpen the blade at the 25° angle, lower the cutting angle to as little as 21° , or increase the cutting angle, all without having to regrind the primary bevel.



Caution: *Be aware that the blade is sharp; careless handling can result in serious injury.*

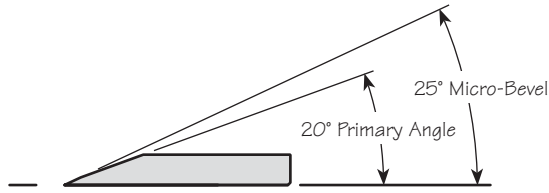

Figure 7: Blade geometry as supplied.

Due to the small size of the blade and the difficulty in holding it while sharpening, you may want to use a sharpening jig or holder. These provide a large clamping surface to firmly hold the blade while hand sharpening or when mounting it to a honing guide. A holder that securely holds small blades against anodized aluminum through the use of a wedge and rare-earth magnets is available from Veritas (05P32.03). You can also make your own holder, as illustrated in **Figures 8** and **9**. The body of the jig is best made from a $\frac{3}{8}$ " thick piece of close-grained hardwood, such as maple or birch. Two #10 $\times \frac{3}{4}$ " long countersunk flat-head machine screws must be used in order to provide the clearance required on the bottom side for honing the low 20° bevel.

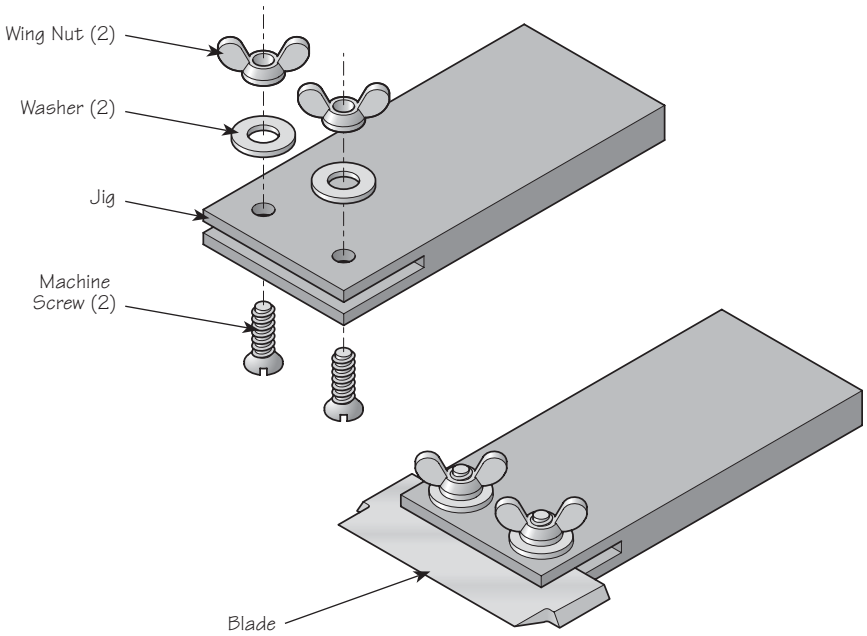

Figure 8: Blade sharpening jig.

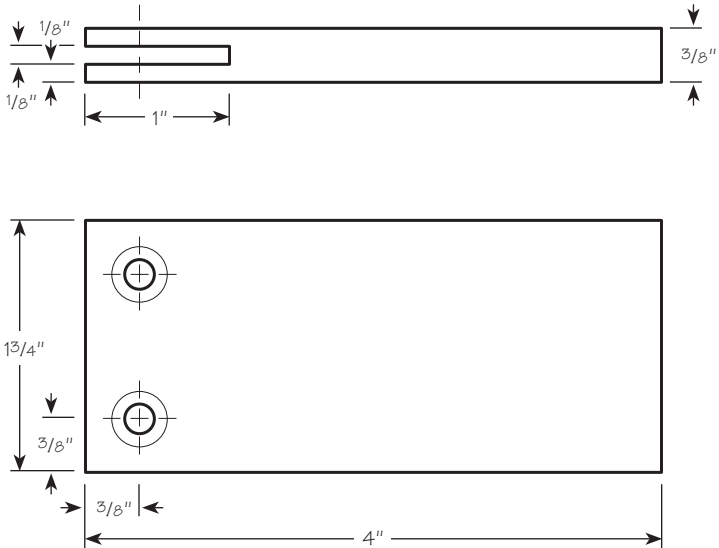

Figure 9: Blade sharpening jig plan.

Accessories

05P32.03 Small-Blade Holder
05P32.02 Replacement Blade

veritas[®] Tools Inc.

814 Proctor Avenue 1090 Morrison Drive
Ogdensburg, New York Ottawa, Ontario
13669-2205 USA K2H 1C2 Canada

481
© Veritas Tools Inc. 2007

customerservice@veritastools.com
www.veritastools.com

INS-160 Rev. E
Printed in Canada.